



## 外曲肘射出機

Outward Toggle Injection Molding Machine

# SA SERIES

# SA Series

“  
高效率 - 生產效率提升15~20%  
高性能 - 射出速度提升20%以上

High Efficiency - Increasing production efficiency 15~20%.  
High Performance - Improving injection speed by 20% ↑ .

”

FCS五十年技術結晶與積累，創造了多樣性的產品及穩定的性能品質，同時也針對各行業不同產品特性，提供差異化技術整合與服務。**SA系列**為FCS全新發表之外曲肘射出機，不僅規格升級，設計也更加優化，外觀造型仍堅持美學與人因工程兼備之要求，更整合高階電控系統優勢，可充分結合FCS工業4.0解決方案，是一款集性能、效能與智能於一體的智能射出成型機，可廣泛應用於家用民生、文具、汽車、3C等產業，鞏固客戶競爭優勢。

With 50 years of technological developments and innovations, FCS offers a new and optimized design with increased performance and reliability for a wide variety of industries.

The new **SA Series** delivers unmatched efficiency with its Outward toggle system. The clamp and injection unit specifications have also been increased to allow our customers more flexibility in the range of molds they can run in the machine. The outside appearance of the machine was developed with friendly ergonomics to make working in and around the machine easy, comfortable and safe for the operator. The KEBA control now offers an enhanced capability to integrate the FCS iMF 4.0 system to assist in making your facility a Smart Injection Molding Machine Plant. Overall, these new enhancements to the SA Series will help our customers increase their competitiveness in the industry and propel them to the next stage in new machine technology.



家用五金製品  
Housewares

建築管件  
PVC fittings

# 展 合優翼 風生水起



## Thriving and Flexible



電子產品外殼  
Electronic product casings

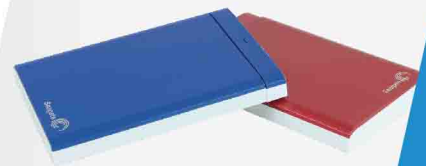

厚件容器  
Thick-wall



汽車部件  
Automotive parts



# 精準的射出單元 Accurate Injection Unit

高混練螺桿  
High mixing screw

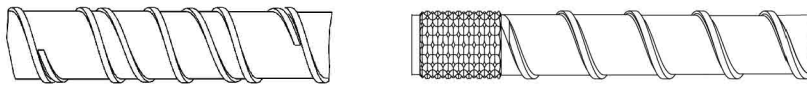

## 高混練螺桿 (選配)

提升L/D比，滿足高射量產品。  
(250 ton以上機型增加D螺桿)

## High mixing screw (optional)

Improve L/D ratio and meet high injection volume products (and add D-screw choice for models above 250 ton).

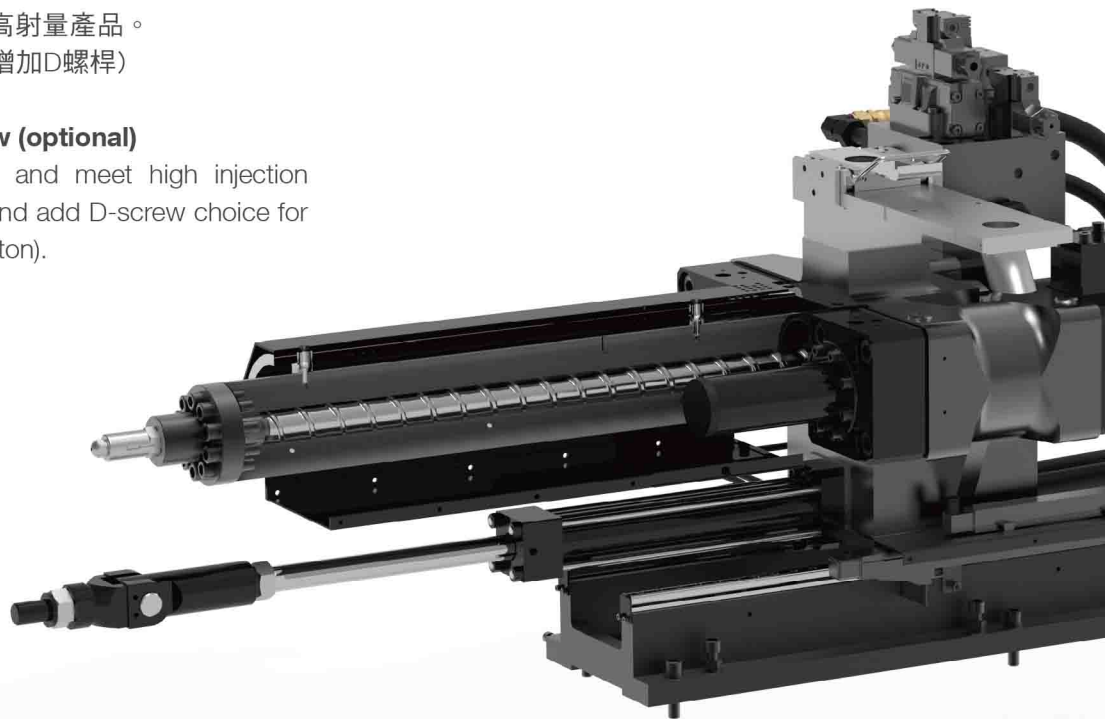

## 射座線性滑軌

- 負荷輕、減少磨耗，射出控制精準穩定。
- 儲料背壓阻力低，減少熔膠溢流。

## Linear guide for the injection carriage

- Lighter load and less abrasion which ensures precise and stable injection.
- Basic charging back pressure to reduce the melt overflow.

### 系統壓力提升

射出油路板與油缸整合優化，提升射出響應速度，擴大產品應用範圍。

### System pressure improvement

The integrated and optimized hydraulic manifold and cylinder, improve the injection response, and expand the product application range.

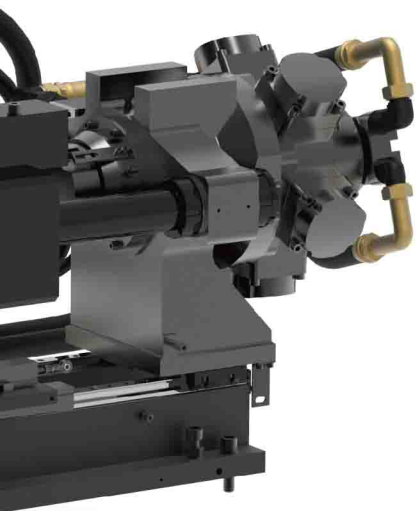

全閉迴路系統 Closed-loop system

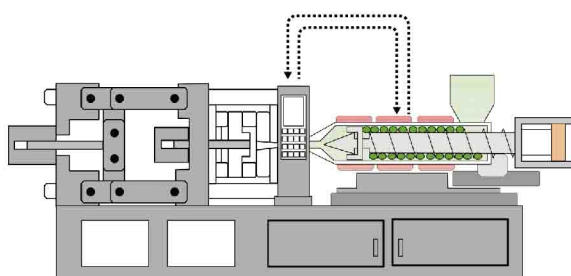

回授螺桿位置於控制器  
Screw position feedback to the controller.

### 伺服射出全閉迴路

精準控制每模射速，射出時間穩定性 >99.9%，成型品重量穩定性佳。

### Servo injection closed-loop system

Accurately controls the injection speed, injection time and shot weight.

### 座進缸前拉設計

減少機架受力，降低變形量，保持穩定射出力。

### Injection carriage forward pull design

Reduce the frame deflection, and maintain a stable injection force.

### 模組化規格選型

提供高速款規格，彈性化滿足食品包裝、薄壁容器等產業需求。

### Optional modular specification

High-speed option is available for food packaging industry and thin-walled product molding requirements.



# 優化的夾模單元 Optimized Clamping Unit

## 夾模長度縮短

夾模長度縮短23%，減少占地空間，提升廠房利用率。

## Mold clamping shortened

The length of the mold clamping unit is shortened by 23% and the floor space is reduced, which could improve plant utilization.

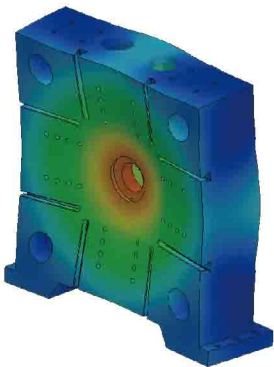
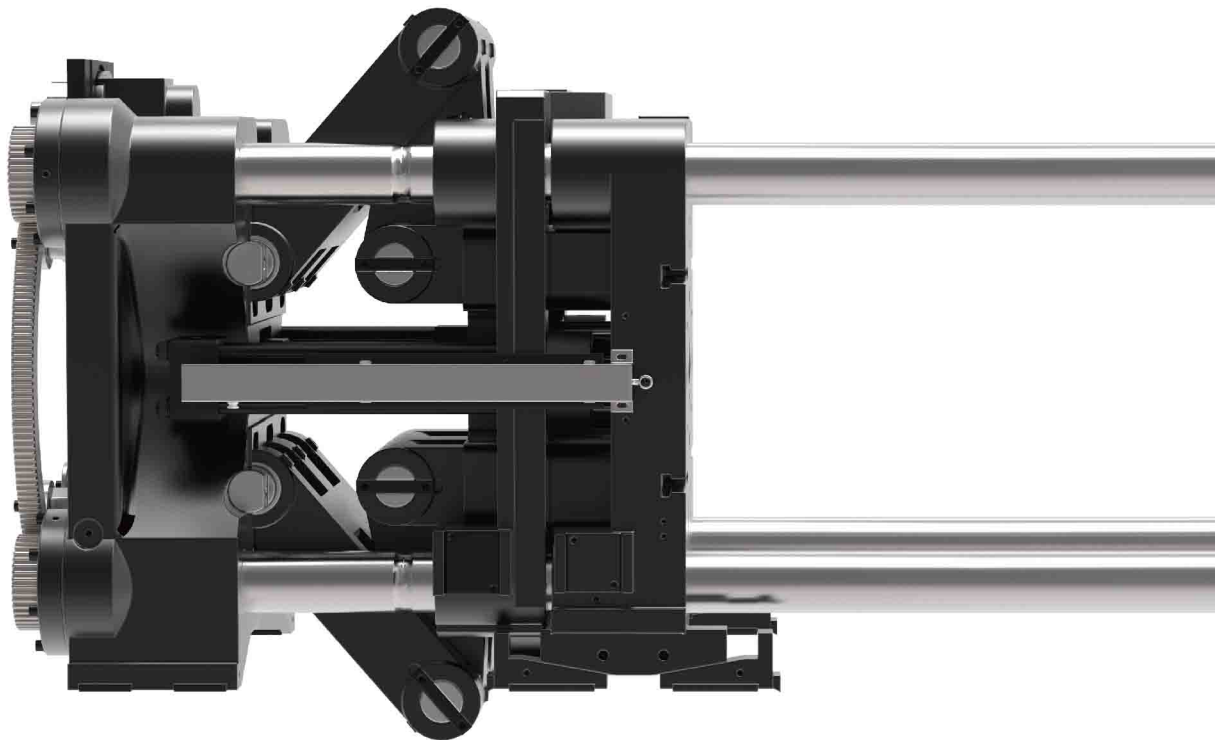

## 模盤強度提升

剛性提升30%，模盤變形量更低，提升模具使用壽命。

## Platen strength improvement

Increase rigidity by 30%, lower deflection of mold plate, and improve the mold lifetime.

### 開模行程增加

開模行程增加16%，適合成型深度較大產品。

### Opening stroke improvement

Increase the mold opening stroke by 16% and suitable for molding plastic products with deep depth.

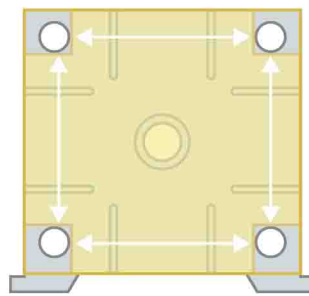

SA Series

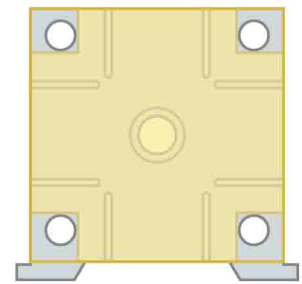

HT Series

### 柱內距加大

模具應用彈性高。

### Tie bar spacing increase

More flexible choices for mold application.

### 活動壁設計優化

- 力流線朝模盤中心集中，可減少模具變形。
- 具強制頂針退回設計功能，滿足模具產品特殊需求。

### Moving platen optimization

- The clamping force flows through the center of the moving platen to help reduce mold wear.
- With mandatory ejector retracting design which meets the needs for special products.

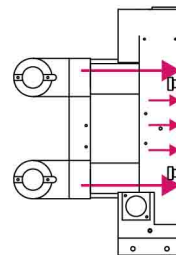

SA Series

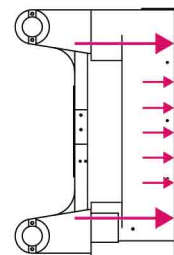

HT Series

# 智能的電控單元 Intelligent Control Unit

## 直覺式操作介面

- 全新設計畫面風格與圖示，操作更為便利。
- 具多階密碼保護功能，記錄與限制各階使用者參數修改。
- 提供統計製程控制及射出波形圖，提高生產品質與效率。
- USB資料存取介面，模具參數、顯示畫面存取便利。
- 採多重通訊介面  
(USB、串行接口、Ethernet、EtherCAT、Sercos III)。
- 支援OPC協定，且依據IEC-61131設計，其特點為模組化並易於軟硬體維護。
- 多種語言可供客戶選擇。

## Intuitive HMI

- New control is designed for easy operator interface.
- The multi-level password protection function is used to record and limit the parameters modification from various levels of users.
- Provide statistical process control and injection waveforms to improve production quality and efficiency.
- Convenient access to USB data, mold parameters and display screens.
- Multiple communication interfaces (USB, serial interface, Ethernet, EtherCAT, Sercos III).
- Control supports OPC protocol and has a modular design to easily maintain the software and hardware.
- Multiple languages are available for users.

## 控制精度

- 加熱控制精度 $0.1^{\circ}\text{C}$ 並有效分段控制，以提升塑化能力。
- 位置控制精度 $0.1\text{mm}$ ，可準確控制動作行程。

## Control Precision

- Barrel heat zones are accurate to 0.1 degree C to ensure stable material plasticizing.
- Screw position is controlled with in 0.1mm to precisely control shot size and cushion position.





# 智慧製造工廠 iMF 4.0

## iMF 4.0 智慧製造工廠 intelligent ManuFactory

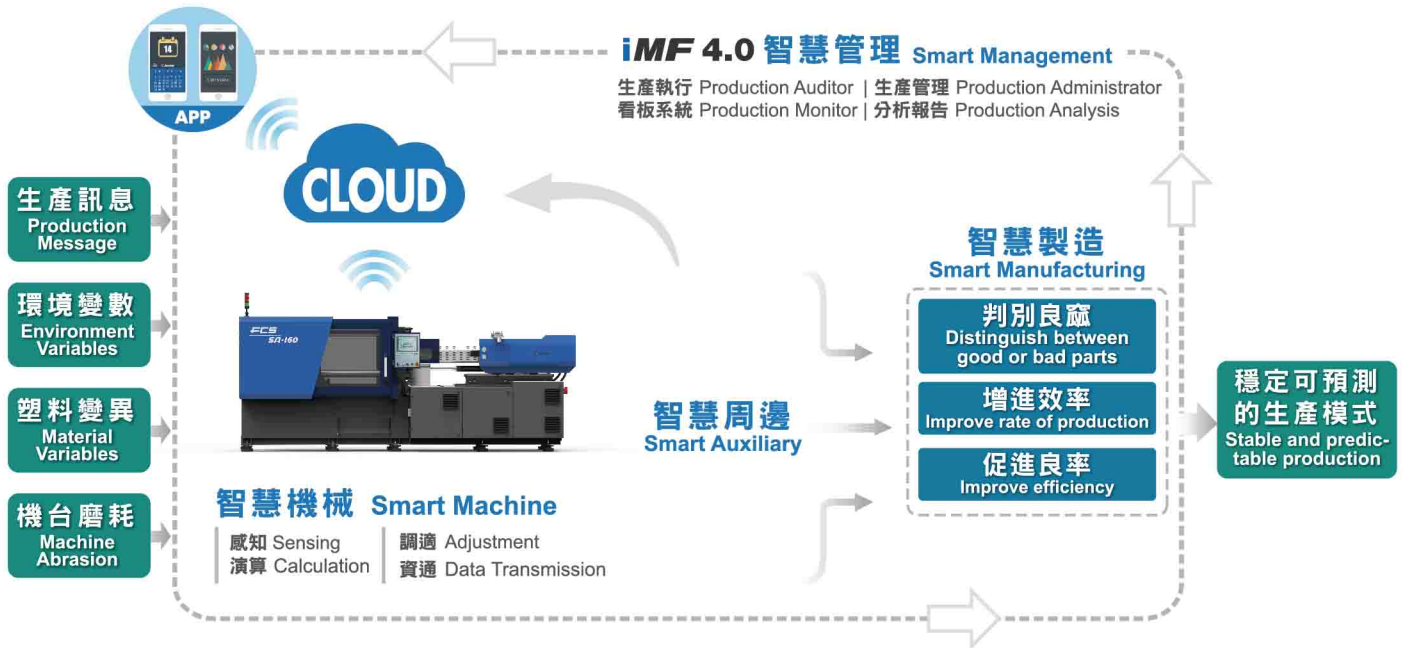

### 遠端監控&工業4.0

- 生產品質記錄。
- 模具資料上傳及下載。
- 機台稼動率及產能統計。
- 機台停機狀態顯示及記錄。
- 可將資訊匯出以進行看板管理。(選配)

### Remote Control & Industry 4.0

- Production quality recording.
- Mold information upload and download.
- Machine utilization rate and production capacity statistics.
- Machine downtime status display and recording.
- Information can be exported for visual management. (Optional)

控制器 Control	FCS 6500S	FCS 6500 (Optional)
螢幕尺寸 Screen Size	10"	12"
操作方式 Operation Method	按鍵 Button	按鍵&觸控 Button & Touch
反應時間 Reaction Time	2ms	1ms
螢幕顯示 Screen Display	• 800x600 像素 • 800x600 pixel	• 1600 萬色真彩顯示 • 16 million color palettes

# 標準與選購配備 Standard & Optional Accessories

配備項目	ITEM
射出安全護罩	Safety cover for injection
射出止逆裝置	Shot-off Nozzle
PVC、PC、壓克力、尼龍專用螺桿組	Special Screw for PC/PMMA/PA/PVC...
雙合金螺桿、料管	Bi-alloy Screw/Barrel
托拉式落料裝置	Sliding material feeding device
曲手：無給油軸承	Oiliness bearing (Toggle)
曲手：套鋼	Steel bearing(Toggle)
模壁T型槽	T-slot platen
隔熱墊板	Insulator sheets
活動式模定位圈	Check ring of mold (Replaceable)
成品落下口	Article Collecting Channel
電動安全門	Automatic safety gate (Electric type)
機械安全桿保護裝置	Mechanical Safety bar Protection device
水流分佈器8入8出(銅製)	Water manifold - 8 in & 8 out (copper)
水流分佈器10入10出(銅製)	Water manifold - 10 in & 10 out (copper)
水流分佈器20入20出(銅製)	Water manifold - 20 in & 20 out (copper)
*全罩式鈹金(射出)	Whole machine housing (Injection)
*全罩式鈹金(夾模)	Whole machine housing (Clamping)
強制托退	Ejector pull back
電眼檢出	Photo cell drop-out checking device
成品落下板	Finished drop board
車壁潤滑：電動注油器	Auto Manual lubrication(platen)
開關模比例閥控制	Proportional valve for mould open and close
多段數位背壓(螢幕設定及顯示)	Multi-stage back pressure control(Screen display)
多段數位背壓(螢幕設定)	Multi-stage back pressure control(Screen set up )
射出閉迴路(伺服閥)	Closed-loop control for injection(servo valve)
曲手電動注油器(1組)	Auto lubrication system for toggle (1 set)
曲手電動注油器(2組)	Auto lubrication system for toggle (2 set)
單中子+止逆(一公)	Single core pulling device
雙中子+止逆(一公一母)	Double core pulling device
四中子+止逆(二公二母)	Double core pulling device
轉牙裝置(計時/計次)	Unscrew device by timer or counter
自封式磁性吸油過濾器	With check valve magnetic suction filter
雙迴路(開模與托模同動)	Double loops system(mold open - ejector start)
雙迴路(開模與加料同動)	Double loops system(mold open - screw charge start)
三迴路(開模、托模與加料同動)	Parallel movement for material charging & mold ejecting during mold opening
伺服節能系統	Servo power-saving system
托模止逆閥	Non-return valve for ejector
射出壓力螢幕顯示	Injection pressure display on screen
射嘴獨立溫控	Temperature control of injection nozzle
落料口溫度顯示	Temperature display of material feeding section
落料口溫度控制	Temperature control of material feeding section
射出電阻尺	Linear potentiometer for injection
射座電阻尺	Linear potentiometer for injection carriage
夾模電阻尺	Linear potentiometer for clamping
托模電阻尺	Linear potentiometer for ejection
兩個風托(一公一母)	Air ejector sets
油溫顯示	Oil temperature display for hydraulic system
油溫顯示及控制	Oil temperature display & control
FCS-6500S微電腦控制器(彩色：KEBA)	FCS-6500S controller(color& key screen:KEBA)
FCS-6500微電腦控制器(彩色觸控：KEBA)	FCS-6500 controller(color & touch screen:KEBA)
電控穩壓器	Power stabilizer for controller
資料保護鎖(硬體鎖)	Data lock function(key)
三色警示燈	Three-color alarm lamp
CE安全插座	CE safty socket
電源插座(110V/220V)	Power socket (110V/220V)
主電源斷路器	Main power breaker
24H料管自動定時預熱	24 hours auto-preheat for barrel sets
氣壓式閥澆口控制閥	Pneumatic type Valve Gate
機械手電氣接口	Robot electrical interface
不銹鋼漏斗	Stainless hopper
乾燥機	Hopper dryer
抽料機	Auto loader
模溫機	Mold temperature controller
乾燥機磁鐵	Magnet of hopper dryer
門式吊桿	Frame hanger
吊桿組	Hanger set for lifting molds
避震器	Anti-vibration mounting pad
填料台	Filling material stand
工具箱組	Tool box
標準出車附件	Spare parts
外銷出車附件	Export accessories



全球行銷服務網  
Global Marketing Network

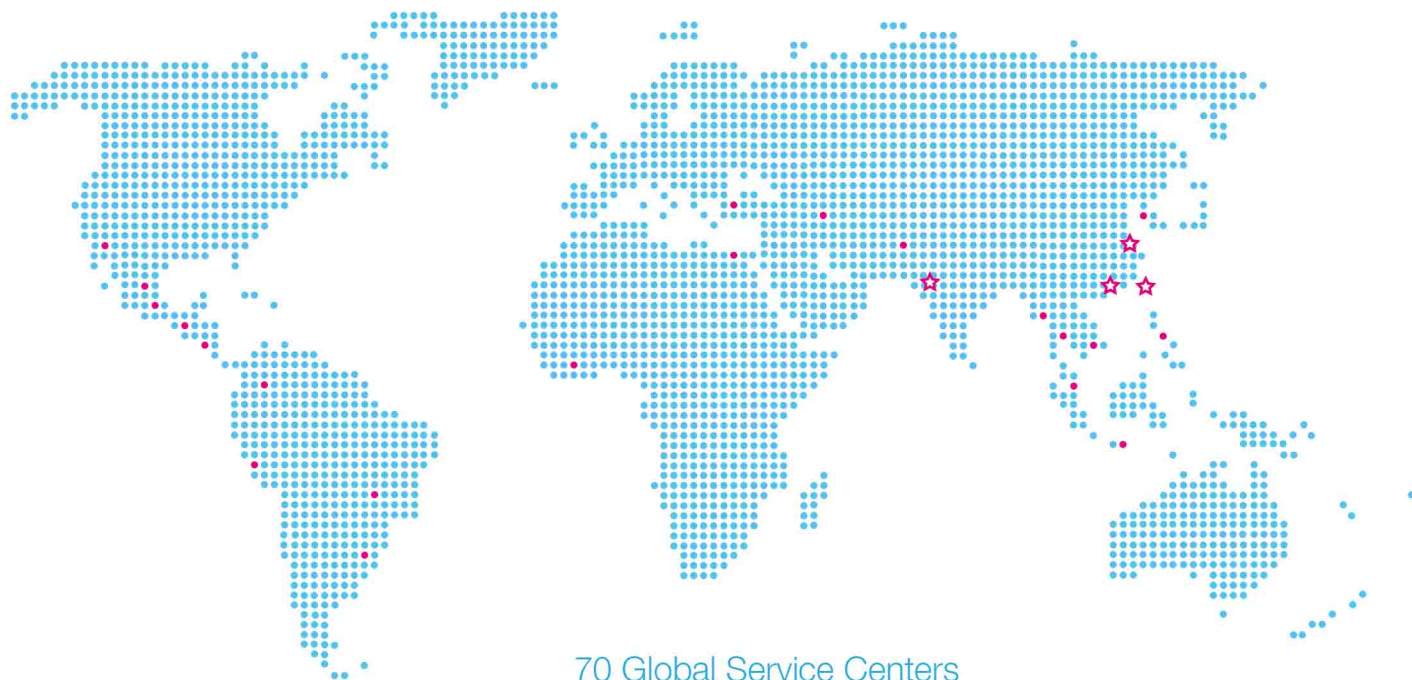

70 Global Service Centers

SA-2023-06-cn/en Copyright © 2023 FCS Group All rights reserved

## 富強鑫集團 FCS Group

**FCS**  
www.fcs.com.tw

### 富強鑫精密工業股份有限公司

Fu Chun Shin Machinery Manufacture Co., Ltd.

71841 臺灣台南市關廟區埤頭里保東路269號  
No.269, Baodong Road, Pitou Village, Guanmiao District, Tainan City 71841, Taiwan  
TEL: +886-6-5950688 • FAX: +886-6-5951129 • E-mail: fcsco@fcs.com.tw

### 東莞富強鑫塑膠機械製造有限公司

Dongguan Fu Chun Shin Plastic Machinery Manufacture Co., Ltd.

廣東省東莞市大朗鎮石廈管理區金廈東路18號 郵編：523792  
No.18, Jinsha East Road, Shixia Administration District, Dalang Town,  
Dongguan City 523792, Guangdong Province, China  
TEL: +86-769-83313753 • FAX: +86-769-83181903 • E-mail: cdg@fcs.com.tw

### 富強鑫(寧波)機器製造有限公司

Fu Chun Shin (Ningbo) Machinery Manufacture Co., Ltd.

浙江省寧波市江北區海川路115號 郵編：315032  
No.115, Haichuan Road, Jiangbei District, Ningbo City 315032, Zhejiang Province, China  
TEL: +86-574-56138688 • FAX: +86-574-56138600 • E-mail: cnb@fcs.com.tw

### 印度富強鑫

FCS Manufacturing (India) Private Limited

Block Number 218, Xcelon Industrial Estate, Near Intas Pharmaceutical, Village Chancharvadi Vasna,  
Sarkhej Bavla Road, Taluka Sanand, Ahmedabad, Gujarat - 382213  
TEL: +91-99-98897768 • E-mail: fcsindia@fcs.com.tw

